

SENTENCIA

Smart softener





SENTENCIA

Smart softener

11L / 15L / 20L / 26L / 32L

Our Sentencia water softeners are the perfect solution for eliminating hard water without investing all your savings in a softening system.



FEATURES

- ◆ Multilingual software
- ◆ One-line backlit display
- ◆ Easy programming
- ◆ Large salt storage capacity
- ◆ Compact size
- ◆ Salt alarm

BENEFITS

- ➔ User-friendly with the optimal legibility of settings and statistics
- ➔ Plug and play - pre-set to perform at its best
- ➔ Simplified salt load operation
- ➔ Particularly suitable for installations where space-saving is important
- ➔ Never run out of salt without noticing

TECHNICAL SPECIFICATIONS

CHARACTERISTICS	Sentencia CS mini 0917 11l	Sentencia CS midi 0924 15l	Sentencia CS midi 1024 20l	Sentencia CS maxi 0935 26l	Sentencia CS maxi 1035 32l
Part number	4035627	4035628	4035629	4035630	4035631
Resin Volume (L)	11 L	15 L	20 L	26 L	32 L
Number of People	1-2	3-4	5-6	7-8	7-8
Nominal flow rate (m ³ /h) (residual hardness 0°f)	0,7 m ³ /h	0,9 m ³ /h	1,2 m ³ /h	1,6 m ³ /h	1,9 m ³ /h
Nominal flow rate (m ³ /h) (residual hardness 5-10°f)	0,8 m ³ /h	1,1 m ³ /h	1,4 m ³ /h	1,9 m ³ /h	2,3 m ³ /h
Peak flow rate (m ³ /h) (residual hardness 5-10°f)	1,1 m ³ /h	1,5 m ³ /h	2,0 m ³ /h	2,6 m ³ /h	3,2 m ³ /h
Salt dosage g/resin (standard settings)	125 g/l	125 g/l	125 g/l	125 g/l	125 g/l
Salt consumption per regeneration (kg)	1,4 kg	1,9 kg	2,5 kg	3,3 kg	4,0 kg
Water consumption per regeneration (L)	64 L	86 L	122 L	141 L	169 L
Softener capacity °f x m ³	55,2 °f • m ³	75,3 °f • m ³	100,4 °f • m ³	130,5 °f • m ³	160,6 °f • m ³
Capacity in m ³ for 30°f inlet water hardness and 10°f residual hardness setting	2,8 m ³	3,8 m ³	5,0 m ³	6,5 m ³	8,0 m ³
In / out connections	3/4" BSPT	3/4" BSPT	3/4" BSPT	3/4" BSPT	3/4" BSPT
Drain connection	1/2" hose	1/2" hose	1/2" hose	1/2" hose	1/2" hose
Tank size	9x17	9x24	10x24	9x35	10x35
Operating pressure min/max (bar)	1,4 / 8,3				
Operating temperature min/max(°C)	2 / 48				
Electrical connection (V/Hz)	100-230/24VDC - 50/60 Hz				
Max power consumption (VA)	6,5 VA				
Accessories included	Voltage transformer 230-24V - 3/4" or 1" BSP male in/out connection kit, 3 mtr reinforced drain hose with 4 clamps				
Regeneration type	Upflow 5 cycles with proportional bring				
System interface	Multilanguage electronic display 2 lines x 16 character				
Salt compartment capacity in kg	125,0 kg	75,0 kg	125,0 kg	50,0 kg	75,0 kg
Product width	345 mm	345 mm	345 mm	345 mm	345 mm
Product height	683 mm	817 mm	817 mm	1103 mm	1103 mm
Product depth	573 mm	573 mm	573 mm	573 mm	573 mm
Product depth with bypass assembled	658 mm	658 mm	658 mm	658 mm	658 mm
Product weight	18,5 kg	24,0 kg	28,5 kg	35,5 kg	41,0 kg
Packaging dimension (WxLxH) mm	360x600x610	360x600x770	360x600x770	360x600x1020	360x600x1020
Quantity per pallet	18	12	12	12	12
Pallet dimensions (WxLxH) mm	1170x1230x2320	1170x1230x1860	1170x1230x1860	1170x1230x2440	1170x1230x2440

Note: All calculations are based on a salt dosage setting standard of the PCB. The softener installation takes into account a pre-filter made of a 10" filter housing (Pentair ref. 150543) and a 10" 100micron Wound cartridge (Pentair ref. WWP100P10).

* Indicatives data. Maximum flow rate to produce in order to respect the required service velocity for an optimal ion exchange upon resin manufacturers recommendation, regardless of the inlet pressure.

** Values may vary upon local condition and programming. All consumptions are given for an inlet pressure of 3 bar.

OUTLINE DRAWINGS

Sentencia CS mini 11

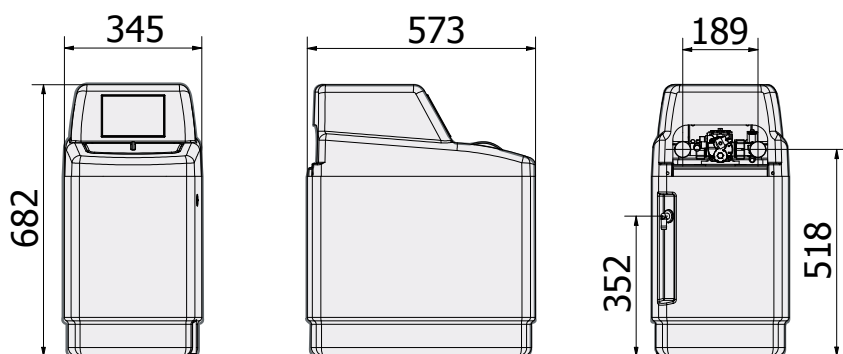

Sentencia CS midi 20

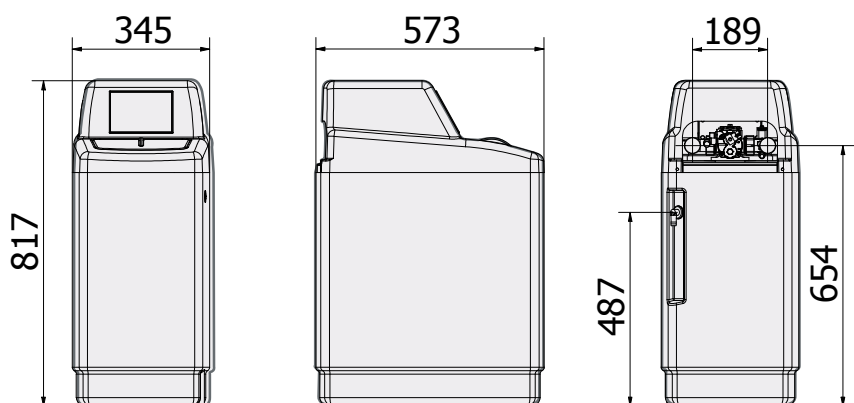

Sentencia CS maxi 32

