

SLIMLINE

Smart softener



SLIMLINE

Water softener

11L / 14L / 17L / 24L / 30L



Our Slimline water treatment systems protect you and your home.

The Slimline water softeners are equipped with the latest technology. This way they deliver the best performance and guarantee a carefree water supply.

FEATURES

- ◆ Multilingual, two-line, legible display
- ◆ Separate salt light
- ◆ Easy programming, with all settings, except hardness and time, factory-set
- ◆ Integrated handles
- ◆ Compact cabinet design
- ◆ High efficiency up-flow regeneration with proportional brining
- ◆ Salt alarm

BENEFITS

- ➔ User-friendly with the optimal legibility of settings and statistics
- ➔ Simplified salt load operation
- ➔ Plug and play : pre-set to perform at its best
- ➔ Simple and easy installation
- ➔ Particularly suitable for installations where space-saving is important
- ➔ Exceptionally low rinse water usage per regeneration leads to minimal salt consumption, with up to 40% salt-saving compared to standard softeners
- ➔ Never runs out of salt without noticing

TECHNICAL SPECIFICATIONS

CHARACTERISTICS	Slimline CS mini 1015	Slimline CS mini 1015	Slimline CS midi 0922	Slimline CS maxi 0930	Slimline CS maxi 1030
Part number	4035289	4035386	4035290	4035291	4035387
Resin volume (L)	11 L	14 L	17 L	24 L	30 L
Number of People	1-2	3-4	5-6	7-8	7-8
Nominal flow rate (m ³ /h) (residual hardness 0°f)	0,7 m ³ /h	0,8 m ³ /h	1,0 m ³ /h	1,4 m ³ /h	1,8 m ³ /h
Nominal flow rate (m ³ /h) (residual hardness 5-10°f)	0,8 m ³ /h	1,0 m ³ /h	1,2 m ³ /h	1,7 m ³ /h	2,2 m ³ /h
Peak flow rate (m ³ /h) (residual hardness 5-10°f)	1,1 m ³ /h	1,4 m ³ /h	1,7 m ³ /h	2,4 m ³ /h	3,0 m ³ /h
Salt dosage g/resin (standard settings)	125 g/l				
Salt consumption per regeneration (kg)	1,4 kg	1,8 kg	2,1 kg	3,0 kg	3,7 kg
Water consumption per regeneration (L)	82 L / 55 L	117 L / 64 L	134 L / 74 L	185 L / 96 L	243 L / 115 L
Softener capacity °f x m ³	55,2 °f • m ³	70,3 °f • m ³	85,3 °f • m ³	120,5 °f • m ³	150,6 °f • m ³
Capacity in m ³ for 30°f inlet water hardness and 10°f residual hardness setting	2,8 m ³	3,5 m ³	4,3 m ³	6,0 m ³	7,5 m ³
In / out connections	3/4" BSPT	3/4" BSPT	3/4" BSPT	3/4" BSPT	3/4" BSPT
Drain connection	1/2" hose	1/2" hose	1/2" hose	1/2" hose	1/2" hose
Tank size	10x15	10x15	9x22	9x30	10x30
Operating pressure min/max (bar)	1,4 / 8,3				
Operating temperature min/max (°C)	2 / 48				
Electrical connection (V/Hz)	100-230/24VDC - 50/60 Hz				
Max power consumption (VA)	6,5 VA				
Accessories included	Plastic bypass, with incorporated mixing valve - Voltage transformer 230-24V 3/4 BSP male in/out connection kit - 3 mtr reinforced drain hose with 2 clamps Air gap with double drain connection				
Regeneration type	Upflow 5 cycles with proportional brining				
System interface	Multilanguage electronic display 2 lines x 16 character				
Salt compartment capacity in kg	25,0 kg	25,0 kg	37,0 kg	65,0 kg	65,0 kg
Product width	352 mm	352 mm	352 mm	391 mm	391 mm
Product height	546 mm	546 mm	680 mm	965 mm	965 mm
Product depth	442 mm	442 mm	442 mm	467 mm	467 mm
Product depth with bypass assembled	525 mm	525 mm	525 mm	550 mm	550 mm
Product weight	19,5 kg	21,5 kg	25,0 kg	35,5 kg	41,0 kg
Packaging dimension (WxLxH) mm	390x480x580	390x480x580	390x480x710	390x480x1010	390x480x1010
Quantity per pallet	18	18	12	12	12
Pallet dimensions (WxLxH) mm	1030x1230x2200	1030x1230x2200	1030x1230x1800	1030x1230x2240	1030x1230x2240

Note: All calculations are based on a salt dosage setting standard of the PCB. The softener installation takes into account a pre-filter made of a 10" filter housing (Pentair ref. 150543) and a 10" 100micron Wound cartridge (Pentair ref. WWP100P10).

* Indicatives data. Maximum flow rate to produce in order to respect the required service velocity for an optimal ion exchange upon resin manufacturers recommendation, regardless of the inlet pressure.

** Values may vary upon local condition and programming. All consumptions are given for an inlet pressure of 3 bar.



OUTLINE DRAWINGS

Slimline CS mini 1015 11L

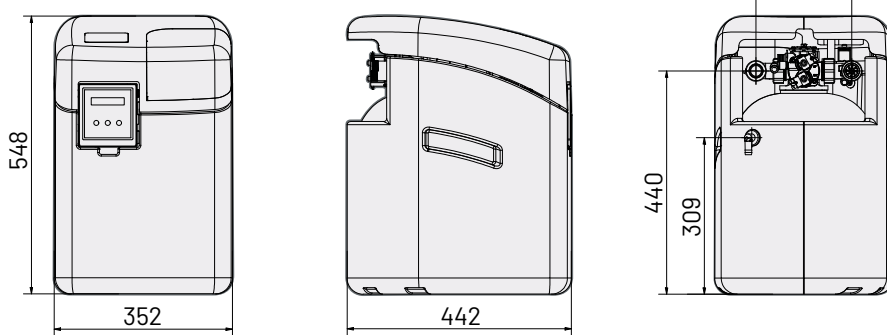

Slimline CS midi 0922 17L

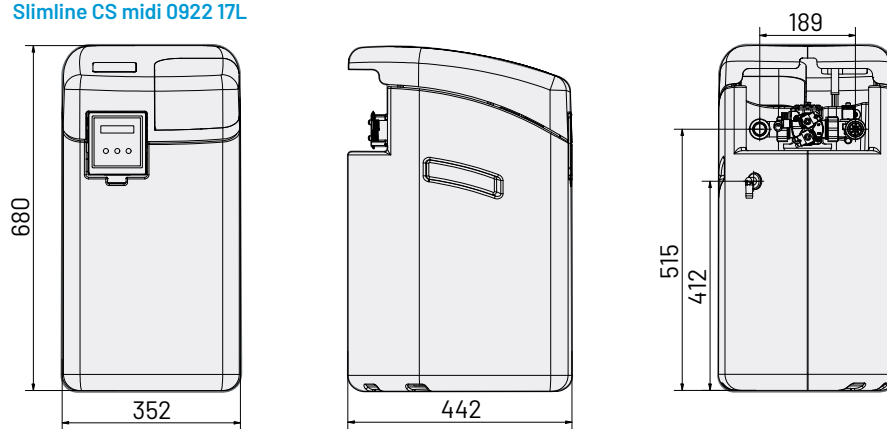

Slimline CS maxi 1030 30L

